

TIGER BATCHING & MIXING SPECIFICATIONS & FEATURES

Please discuss your plant requirements with a TIGER representative. Our TIGER team of experts in the field of concrete product manufacturing are ready to assess your needs and provide the equipment that best suits your requirements. Let us help you identify the correct Batching & Mixing machinery to fit your product applications.

DM-81

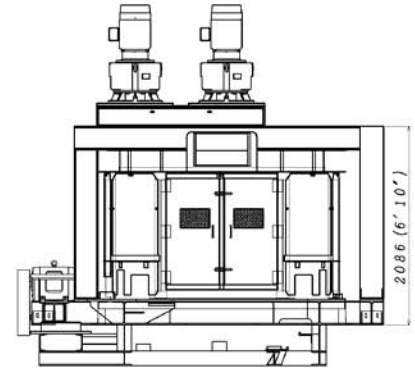
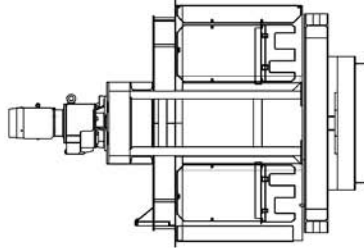
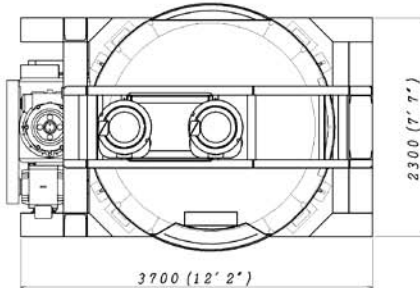

Download these and other TIGER technical specifications at www.tigermachine.com/resources

DM SERIES BATCH MIXERS - TURBINE TYPE

Features	DM-8	DM-24	DM-36	DM-48	DM-60	DM-81
Air operated gate	Std.	Std.	Std.	Std.	Std.	Std.
Hydraulically operated gate	N/A	N/A	N/A	N/A	N/A	N/A
Drive clutch - air/direct drive	Direct, Chain	Direct, Chain	Direct, Chain	Direct, Chain	Direct, Chain	Direct, Chain
Motor(s) and base	Std.	Std.	Std.	Std.	Std.	Std.
Oil filled gear housing	Std.	Std.	Std.	Std.	Std.	Std.
Pulley guard	Std.	Std.	Std.	Std.	Std.	Std.
Totally enclosed drum	Std.	Std.	Std.	Std.	Std.	Std.
Discharge gate vibrator, pneumatic piston	N/A	Std.	Std.	Std.	Std.	Std.
Cleanout gate - manul	Std.	Std.	Std.	Std.	Std.	Std.
Liners w/moisture sensor probes	Std.	Std.	Std.	Std.	Std.	Std.
Specification						
Drum and agitator drive motor kW	7.5 kW	18.5 kW	30 kW	N/A	N/A	N/A
Drum drive motor(s) kW	N/A	N/A	N/A	15 kW x 1 pc.	22 kW x 1 pc.	22 kW x 1 pc.
R.P.M. of the drum	8.8 RPM	11.4 RPM	11.4 RPM	7.5 RPM	7.5 RPM	7.5 RPM
Agitator drive motor(s) kW	N/A	N/A	N/A	15 kW x 2 pcs.	15 kW x 2 pcs.	22 kW x 2 pcs.
R.P.M. of Agitator(s)	81.5	54.3	54.3	36	36	36
Compressed air requirements m3/min-cu ft/min	0.05 m3	0.75 m3	0.75 m3	0.6 m3	0.6 m3	0.6 m3
Compressed air pressure required MPa/psi	7 MPa	7 MPa	7 MPa	7 MPa	7 MPa	7 MPa
Water inlet pipe size (diameter) mm/in	27.2 mm / 3/4"	34 mm / 1"	34 mm / 1"	42.7 mm / 1-1/4"	42.7 mm / 1-1/4"	42.7 mm / 1-1/4"
Productivity						
Maximum dry capacity kgs/lbs	300 Kg	1100 Kg	1600 Kg	2300 Kg	2750 Kg	3200 Kg
Mixer volume size & rating	0.15 m3	0.5 m3	0.7 m3	1.0 m3	1.2 m3	1.5 m3
Options						
Moisture meter system	available	available	available	available	available	available
Mixer dimensions						
Approximate width mm	1760 mm	3300 mm	3300 mm	3700 mm	3700 mm	3700 mm
Approximate height mm	1650 mm	1890 mm	2030 mm	1890 mm	1900 mm	2100 mm
Approximate length mm	1100 mm	1650 mm	1650 mm	2300 mm	2300 mm	2300 mm
Approximate shipping weight (net) kgs	2300 kg	5000 kg	7000 kg	13300 kg	13500 kg	13700 kg

JOIN THE CONCRETE REVOLUTION!

TIGER reserves the right to change, discontinue or improve product design and specifications without prior notice.



NATIONAL
CONCRETE MASONRY
ASSOCIATION

Tiger International, Inc.
Worldwide Sales
PO Box 2288 • Portage, MI 49081-2288 – U.S.A.
Phone: 269.353.8722 • Fax: 269.353.8723
www.tigermachine.com



ICPI
INTERLOCKING CONCRETE
PAYMENT INSTITUTION

Tiger Machine Co., Ltd.
World Headquarters
2327 Abe Ochiai-Cho, Takahashi-Shi
Okayama-Ken, 716-0061 – Japan
Phone: +81-866-22-2927 • Fax: +81-866-22-2844



Pathfinder Systems
Canada and U.S. Sales
695 Ottawa Beach Road • Holland, Michigan 49424
Phone: 616-395-8447 • Fax: 616-395-5995