

TIGER L & M SERIES SPECIFICATIONS & FEATURES

Please discuss your plant requirements with a TIGER representative. Our TIGER team of experts in the field of concrete product manufacturing are ready to assess your needs and provide the equipment that best suits your requirements. Let us help you identify the correct L or M Series machine to fit your product applications.

M-4

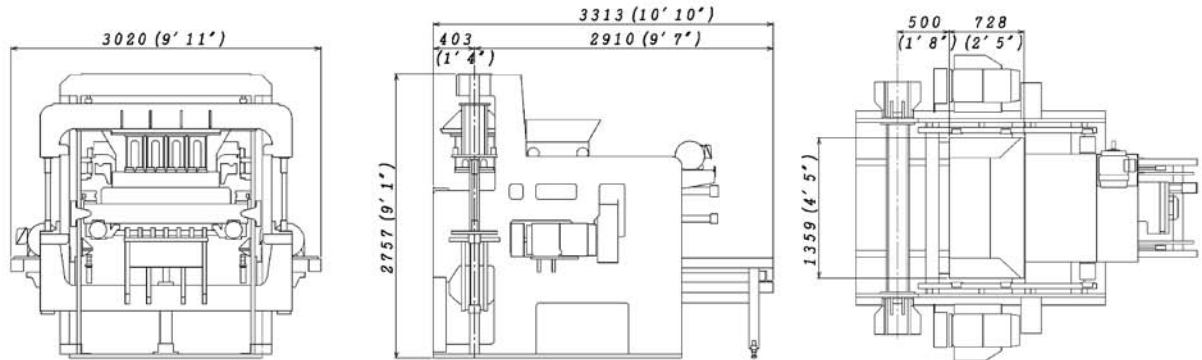

Download these and other TIGER technical specifications at www.tigermachine.com/resources

L & M Series Machines

Available with:	L-2	M-2J	M-2	M-3	M-4	M-4S
Offbearing hoist systems	OK	OK	OK	OK	OK	N/A
Rack loader & unloader systems	N/A	OK	OK	OK	OK	OK
Rack transfer systems (CR or RTS)	N/A	OK	OK	OK	OK	OK
Cuber Systems	N/A	OK	OK	OK	OK	OK
Features						
Vibrator motors - kW	3.7kW X 2 pcs.	3.7kW X pcs.	5.5kW X 2 pcs.	5.5 kW X 2 pcs.	7.5 kW X 2 pcs.	7.5 kW X 2 pcs.
Pump motor - kW	7.5 kW	11.0 kW	18.5 kW	22.0 kW	22.0 kW	22.0 kW
Hydraulic Pump - Liter per minute	70 liters	90 liters	120 liters	156 liters	156 liters	156 liters
Oil Cooling Fan/Heat exchange motor - kW	0.07 kW	0.14 kW	0.2 kW	0.07kW	0.07 kW	0.07 kW
Hydraulic oil reservoir/Tank - Liters	300 liters	370 liters	480 liters	450 liters	450 liters	450 liters
Recirculating pump motor - kW	0.25 kW	1.5 kW	1.5 kW	0.4 kW	0.4 kW	0.4 kW
Recirculating pump - Liters per minute	70	90	120	156	156	156
Hydraulic system pressure - MPa	6 MPa	7 MPa	12 MPa	9 MPa	9 MPa	9 pma
Rotary agitator motor size - kW	1.5 kW	1.5 kW	2.2 kW	3.7 kW	3.7 kW	5.5 kW
Capacity						
Steel pallet size - mm	430 x 470 x 8	430 x 470 x 8	500 x 470 x 8	660 x 470 x 8	940 x 470 x 12	940 x 520/660 x 12
Useable mold cavity - mm	410 x 450 x 60/215	410 x 450 x 60/215	480 x 450 x 60/215	650 x 450 x 60/215	920 x 450 x 60/250	920 x 500/640 x 60/215
Productivity						
Average dry cycle speed in seconds	7.2	6.8	4.9	6.7	6.7	7.0
Average wet cycles speed in seconds	13.0	12.5	9.0	11.0	11.0	13.0
Average cycles per minute	4.62	4.80	6.67	5.45	5.45	4.62
Concrete masonry units per cycle/pallet						
10 cm/4" block per cycle/pallet	4	4	4	6	9	9
12 cm/5" block per cycle/pallet	3	3	3	5	7	7
15 cm/6" block per cycle/pallet	2	2	3	4	6	6
20 cm/8" block per cycle/pallet	2	2	2	3	4	4
25 cm/10" block per cycle/pallet	1	1	1	2	3	3
30 cm/12" block per cycle/pallet	1	1	1	2	3	3
Holland-Stone pavers 10 x 20 cm	5	6	8	12	18	20
Dimensions & Weight						
Weight	3000 kg (6600 lbs)	3500 kg (7700 lbs)	4000 kg (8800 lbs)	5000 kg (11000 lbs)	6000 kg (13200 lbs)	6200 kg (13600 lbs)
Machine size (W x H x L) - mm	2230 x 2300 x 2460	2330 x 2410 x 2500	2400 x 2540 x 3100	2750 x 2800 x 3320	3100 x 2800 x 3320	3100 x 2800 x 3800
Machine size (W x H x L) - inches	88" x 91" x 97"	82" x 95" x 98"	95" x 100" x 122"	108" x 110 x 131"	122" x 110" x 131"	122" x 110" 131"

JOIN THE CONCRETE REVOLUTION!

TIGER reserves the right to change, discontinue or improve product design and specifications without prior notice.



NATIONAL
CONCRETE MASONRY
ASSOCIATION

Tiger International, Inc.
Worldwide Sales
PO Box 2288 • Portage, MI 49081-2288 – U.S.A.
Phone: 269.353.8722 • Fax: 269.353.8723
www.tigermachine.com



ICPI
INTELLIGENT CONCRETE
PAYMENT INSTITUTION

Tiger Machine Co., Ltd.
World Headquarters
2327 Abe Ochiai-Cho, Takahashi-Shi
Okayama-Ken, 716-0061 – Japan
Phone: +81-866-22-2927 • Fax: +81-866-22-2844



Pathfinder Systems
Canada and U.S. Sales
695 Ottawa Beach Road • Holland, Michigan 49424
Phone: 616-395-8447 • Fax: 616-395-5995