

TIGER MULTI-PRO SERIES SPECIFICATIONS & FEATURES

Please discuss your plant requirements with a TIGER representative. Our TIGER team of experts in the field of concrete product manufacturing are ready to assess your needs and provide the equipment that best suits your requirements. Let us help you identify the correct J Series machine to fit your product applications.

PS-100V-300H

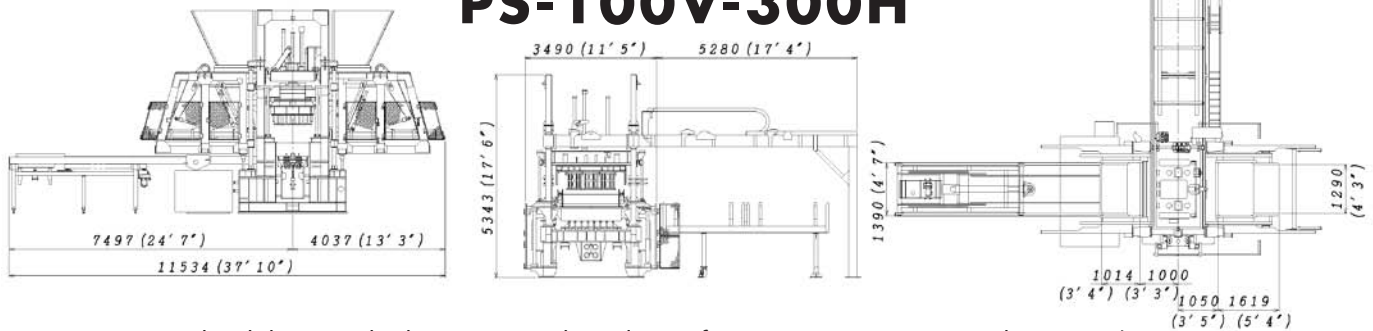

Download these and other TIGER technical specifications at www.tigermachine.com/resources

MULTI-PRO SERIES CONCRETE PRODUCTS MACHINES - SPECIFICATION

Available with:	PS-100V-250H	PS-100V-300H
Offbearing hoist system	N/A	N/A
Rack loader & unloader systems	N/A	N/A
Rack transfer systems (CR or RTS)	OK	OK
Pallet transporter systems (PTS)	OK	OK
Single pallet handling systems (SPH)	OK	OK
Cuber systems	OK	OK
Features		
Vibrator motors - kW	37 kW (49.3 hp)	37 kW (49.3 hp)
Pump motor - kW	55 kW (73.3 hp)	55 kW (73.3 hp)
Hydraulic pump - Liter Per Minute	315 liters (82.8 Gallons)	315 liters (82.8 Gallons)
Oil Cooling Fan/Heat Exchange Motor kW	0.4 kW (0.53 hp)	0.4 kW (0.53 hp)
Hydraulic oil reservoir/Tank - Liters	750 liters (197.3 Gallons)	750 liters (197.3 Gallons)
Recirculating pump motor - kW	2.2 kW (2.93 hp)	2.2 kW (2.93 hp)
Recirculating pump - Liters per minute	138 liters (36.3 Gallons)	138 liters (36.3 Gallons)
Hydraulic system pressure - MPa	15.5/17 MPa (2240/2465 psi)	15.5/17 MPa (2240/2465 psi)
Rotary agitator motor size -kW	Hydraulic	Hydraulic
Compression head vibration	Standard - 2.2 kW (2.9 hp) x 2 pcs.	Standard - 2.2 kW (2.9 hp) x 2 pcs.
Capacity		
Steel pallet size - mm	1400 x 1100 x 16	1400 x 1100 x 16
Steel pallet size - inches	55.12" x 43.31" x 0.62"	55.12" x 43.31" x 0.62"
Useable mold cavity - mm	1360 x 1060 x 30-254	1360 x 1060 x 30-254
Useable mold cavity - inches	53.54" x 41.73" x 1.18" x 10"	53.54" x 41.73" x 1.18" x 12"
Productivity		
Average dry cycle speed in seconds	6.7	6.7
Average wet cycle speed in seconds	12	12
Average cycles per minute	5.00	5.00
Concrete masonry units per cycle/pallet		
10 cm/4" block per cycle/pallet	26	26
12 cm/5" block per cycle/pallet	20	20
15 cm/6" block per cycle/pallet	16	16
20 cm/8" block per cycle/pallet	12	12
25 cm/10" block per cycle/pallet	10	10
30 cm/12" block per cycle/pallet	10	10
Holland-Stone Pavers 10 x 20 cm	54	54
Dimensions & Weight		
Weight	36000 kg (79,200 lbs)	38000 kg (83600 lbs)
Machine size (W x H x L) - mm	2800 x 4750 x 10500	2800 x 4750 x 10500
Machine size (W x H x L) - inches	110.23" x 187" x 413.37"	110.23" x 187" x 413.37"

JOIN THE CONCRETE REVOLUTION!

TIGER reserves the right to change, discontinue or improve product design and specifications without prior notice.



Tiger International, Inc.
Worldwide Sales
PO Box 2288 • Portage, MI 49081-2288 – U.S.A.
Phone: 269.353.8722 • Fax: 269.353.8723
www.tigermachine.com



Tiger Machine Co., Ltd.
World Headquarters
2327 Abe Ochiai-Cho, Takahashi-Shi
Okayama-Ken, 716-0061 – Japan
Phone: +81-866-22-2927 • Fax: +81-866-22-2844



Pathfinder Systems
Canada and U.S. Sales
695 Ottawa Beach Road • Holland, Michigan 49424
Phone: 616-395-8447 • Fax: 616-395-5995