

TIGER

J SERIES SPECIFICATIONS & FEATURES

Please discuss your plant requirements with a TIGER representative. Our TIGER team of experts in the field of concrete product manufacturing are ready to assess your needs and provide the equipment that best suits your requirements. Let us help you identify the correct J Series machine to fit your product applications.

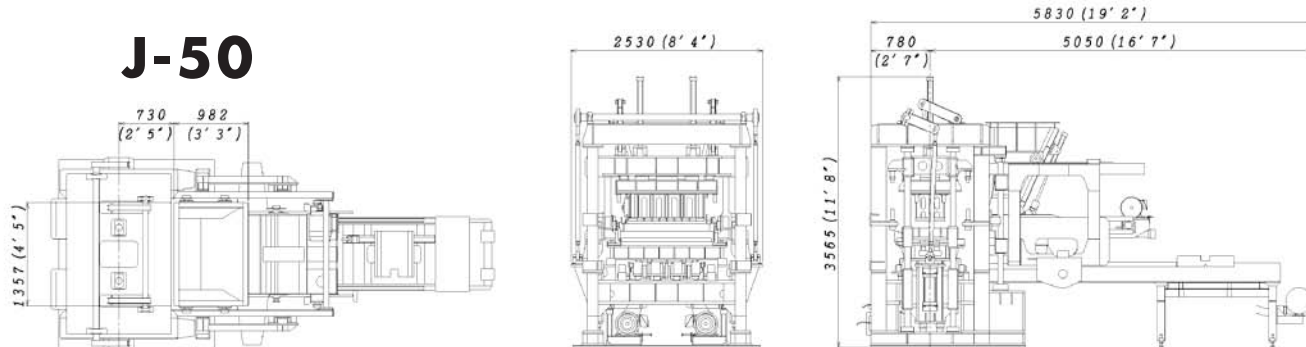

Download these and other TIGER technical specifications at www.tigermachine.com/resources

J SERIES CONCRETE PRODUCTS MACHINES - SPECIFICATION

Available with:	J-50
Offbearing hoist system	OK
Rack loader & unloader systems	OK
Rack transfer systems (CR or RTS)	OK
Pallet transporter systems (PTS)	OK
Single pallet handling systems (SPH)	OK
Cuber systems	OK
Features	
Vibrator motors - kW	3.7 kW (4.9 hp) x pcs.
Pump motor - kW	30 kW (40 hp)
Hydraulic pump - Liter Per Minute	210 liters (55.26 Gallons)
Oil Cooling Fan/Heat Exchange Motor kW	0.4 kW (0.53 hp)
Hydraulic oil reservoir/Tank - Liters	650 liters (171 Gallons)
Recirculating pump motor - kW	2.2 kW (2.9 hp)
Recirculating pump - Liters per minute	138 liters (36.3 Gallons)
Hydraulic system pressure - MPa	12/15 MPa (1740/2175 psi)
Rotary agitator motor size -kW	5.5 kW (7.3 hp)
Compression head vibration	Standard - Pneumatic - Piston-Type
Capacity	
Steel pallet size - mm	978 x 660 x 12
Steel pallet size - inches	38.5" x 26" x 0.46"
Useable mold cavity - mm	950 x 640 x 45/215
Useable mold cavity - inches	37.40" x 25.18" x 1.765" x 8.46"
Productivity	
Average dry cycle speed in seconds	7.4
Average wet cycle speed in seconds	14
Average cycles per minute	4.29
Concrete masonry units per cycle/pallet	
10 cm/4" block per cycle/pallet	9
12 cm/5" block per cycle/pallet	7
15 cm/6" block per cycle/pallet	6
20 cm/8" block per cycle/pallet	4
25 cm/10" block per cycle/pallet	3
30 cm/12" block per cycle/pallet	3
Holland-Stone Pavers 10 x 20 cm	20
Dimensions & Weight	
Weight	16000 kg (32,200 lbs)
Machine size (W x H x L) - mm	2650 x 3600 x 5600
Machine size (W x H x L) - inches	104.65" x 141.73" x 220.46"



JOIN THE CONCRETE REVOLUTION!

TIGER reserves the right to change, discontinue or improve product design and specifications without prior notice.



Tiger International, Inc.
 Worldwide Sales
 PO Box 2288 • Portage, MI 49081-2288 – U.S.A.
 Phone: 269.353.8722 • Fax: 269.353.8723
www.tigermachine.com



Tiger Machine Co., Ltd.
 World Headquarters
 2327 Abe Ochiai-Cho, Takahashi-Shi
 Okayama-Ken, 716-0061 – Japan
 Phone: +81-866-22-2927 • Fax: +81-866-22-2844

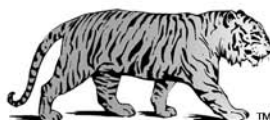

Pathfinder Systems
 Canada and U.S. Sales
 695 Ottawa Beach Road • Holland, Michigan 49424
 Phone: 616-395-8447 • Fax: 616-395-5995