

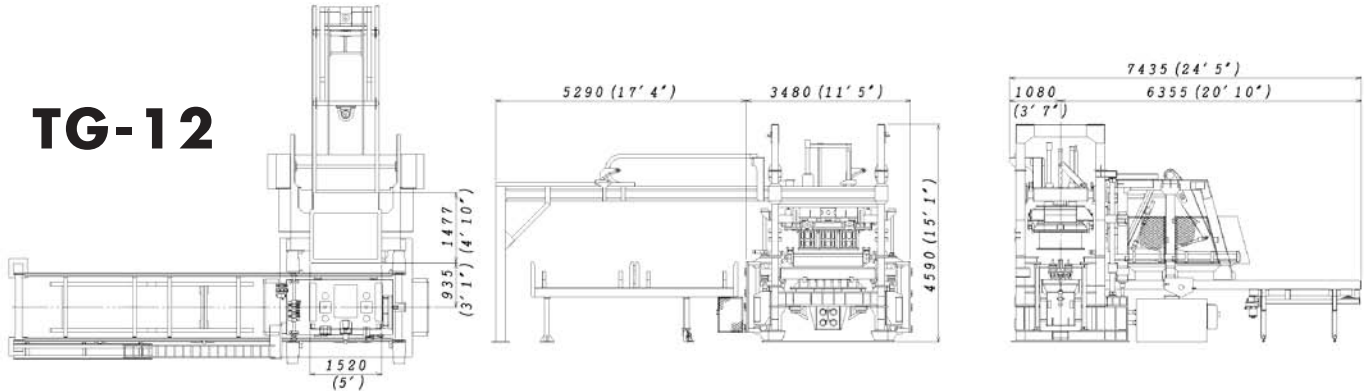

# TG SERIES SPECIFICATIONS & FEATURES

Please discuss your plant requirements with a TIGER representative. Our TIGER team of experts in the field of concrete product manufacturing are ready to assess your needs and provide the equipment that best suits your requirements. Let us help you identify the correct TG Series machine to fit your product applications.



Download these and other TIGER technical specifications at [www.tigermachine.com/resources](http://www.tigermachine.com/resources)

## TG SERIES CONCRETE PRODUCTS MACHINES - SPECIFICATION

Available with:	TG-3	TG-4	TG-5	TG-6	TG-12
Offbearing hoist system	N/A	N/A	N/A	N/A	N/A
Rack loader & unloader systems	OK	OK	N/A	N/A	N/A
Rack transfer systems (CR or RTS)	OK	OK	OK	OK	OK
Pallet transporter systems (PTS)	OK	OK	OK	OK	OK
Single pallet handling systems (SPH)	OK	OK	OK	OK	OK
Cuber systems	OK	OK	OK	OK	OK
<b>Features</b>					
Vibrator motors - kW	30 kW (40 hp)	30 kW (40 hp)	30 kW (40 hp)	30 kW (40 hp)	37 kW (44.93 hp)
Pump motor - kW	45 kW (60 hp)	55 kW (73.3 hp)	55 kW (73.3 hp)	55 kW (73.3 hp)	55 kW (73.3 hp)
Hydraulic pump - Liter Per Minute	315 liters (82 Gallons)	315 liters (82 Gallons)	315 liters (82 Gallons)	315 liters (82 Gallons)	315 liters (82 Gallons)
Oil Cooling Fan/Heat Exchange Motor kW	0.4 kW (0.53 hp)	0.4 kW (0.53 hp)	0.8 kW (1 hp)	0.8 kW (1 hp)	0.8 kW (1 hp)
Hydraulic oil reservoir/Tank - Liters	650 liters (171 Gallons)	650 liters (171 Gallons)	750 liters (197.3 Gallons)	750 liters (197.3 Gallons)	750 liters (197.3 Gallons)
Recirculating pump motor - kW	2.2 kW (2.9 hp)	2.2 kW (2.9 hp)	2.2 kW (2.9 hp)	2.2 kW (2.9 hp)	2.2 kW (2.9 hp)
Recirculating pump - Liters per minute	138 liters (36.3 Gallons)	138 liters (36.3 Gallons)	138 liters (36.3 Gallons)	138 liters (36.3 Gallons)	138 liters (36.3 Gallons)
Hydraulic system pressure - MPa	9.5/14.5 MPa (1370/2100 psi)	9.5/14.5 MPa (1370/2100 psi)	14.5/17 MPa (2100/2465 psi)	14.5/17 MPa (2100/2465 psi)	16/19 MPa (2320/2755 psi)
Rotary agitator motor	Hydraulic	Hydraulic	Hydraulic	Hydraulic	Hydraulic
<b>Capacity</b>					
Steel pallet size - mm	660 x 470 x 8	978 x 470 x 12	1100 x 470 x 13	1320 x 470 x 14	1397 x 1080 x 16
Steel pallet size - inches	26" x 18.5" x 0.31"	38.5" x 18.5" x 0.46"	45" x 3.12" x 18.5" x 0.5"	52" x 18.5" x 0.56"	55" x 42.5" x 0.62"
Useable mold cavity - mm	650 x 450 x 40-215	953 x 470 x 40-215	1080 x 450 x 40-215	1300 x 450 x 40-215	1360 x 1040 x 40-215
Useable mold cavity - inches	25.5" x 17.75" x 1.57" x 8.5"	37.5" x 18.5" x 1.57" x 8.5"	42.5" x 17.75" x 1.57" x 8.5"	51.18" x 17.75" x 1.57" x 8.5"	53.54" x 17.75" x 1.57" x 8.5"
<b>Productivity</b>					
Average dry cycle speed in seconds	4.2	4.2	4.5	4.5	6.7
Average wet cycle speed in seconds	8.5	8.5	10	10	17
Average cycles per minute	7.06	7.06	6.00	6.00	3.53
<b>Concrete masonry units per cycle/pallet</b>					
10 cm/4" block per cycle/pallet	6	9	10	12	26
12 cm/5" block per cycle/pallet	5	7	8	10	20
15 cm/6" block per cycle/pallet	4	6	7	8	16
20 cm/8" block per cycle/pallet	3	4	5	6	12
25 cm/10" block per cycle/pallet	2	3	4	5	10
30 cm/12" block per cycle/pallet	2	3	3	4	8
Holland-Stone Pavers 10 x 20 cm	12	16	20	24	54
<b>Dimensions &amp; Weight</b>					
Weight	20000 kg (44,000 lbs)	25000 kg (55000 lbs)	27000 kg (59400 lbs)	28000 kg (61600 lbs)	31000 kg (68200 lbs)
Machine size (W x H x L) - mm	2800 x 4300 x 5500	3010 x 4300 x 5500	3280 x 4400 x 7040	3490 x 4400 x 7040	3490 x 4590 x 7450
Machine size (W x H x L) - inches	110.93" x 169.29" x 216.53"	118.5" x 169.29" x 216.53"	129.12" x 173.23" x 277.15"	137.40" x 173.23" x 277.15"	137.40" x 180.71" x 293.33"

## JOIN THE CONCRETE REVOLUTION!

TIGER reserves the right to change, discontinue or improve product design and specifications without prior notice.



**Tiger International, Inc.**  
 Worldwide Sales  
 PO Box 2288 • Portage, MI 49081-2288 – U.S.A.  
 Phone: 269.353.8722 • Fax: 269.353.8723  
[www.tigermachine.com](http://www.tigermachine.com)



**Tiger Machine Co., Ltd.**  
 World Headquarters  
 2327 Abe Ochiai-Cho, Takahashi-Shi  
 Okayama-Ken, 716-0061 – Japan  
 Phone: +81-866-22-2927 • Fax: +81-866-22-2844



**Pathfinder Systems**  
 Canada and U.S. Sales  
 695 Ottawa Beach Road • Holland, Michigan 49424  
 Phone: 616-395-8447 • Fax: 616-395-5995